

CW-F 51/4032 H

Ausgabe: A_0116 Version: 01.10

KNOCHE
Maschinenbau GmbH
31542 Bad Nenndorf
Tel.: +49-5723-9476-70
Fax: +49-5723-9476-86
info@knoche-maschinenbau.de
www.knoche-maschinenbau.de

ERSATZTEILLISTE
SPARE PART LIST
LISTE DE PIÉCES

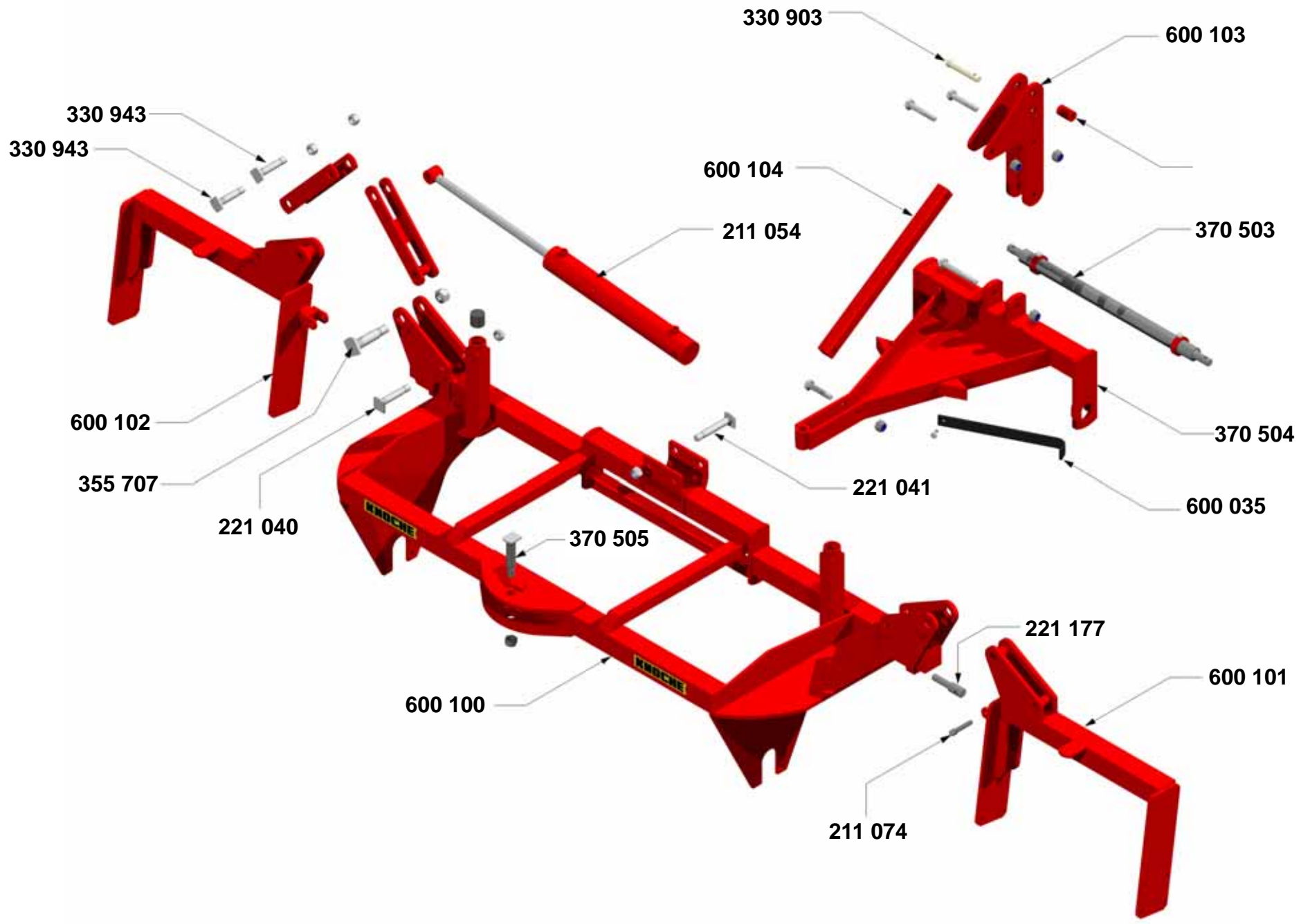



Typ	CW-F 51/4032 H		Baugruppe/ section/ groupe	Hauptrahmen		
-----	-----------------------	--	----------------------------	--------------------	--	--

POS	ID / part-no. réf. article	Benennung / description dénomination	Notiz / note note	Gewicht [kg] weight / poids	Preis [€] price / prix
	211 054	HD-Zylinder 80 x 500 - 6000		18	
	211 074	Steckbolzen Ø 22 - ø 16 - 70 / 105		0,18	
	221 040	Gelenkbolzen 25-115-M24		0,64	
	221 041	Gelenkbolzen Ø 25 - 130 - M 24		0,7	
	221 177	Verriegelungsanschlag D50-140		1	
	330 903	Oberlenkerbolzen KAT II		0,5	
	330 943	Gelenkbolzen M 24 25 x 135		0,55	
	355 707	Gelenkbolzen 35x160 M30		1,72	
	370 503	Fangwelle KAT II-F / Ø50 mit Stellringen		14	
	370 504	Lenkbock FP 25/30			
	370 505	Gelenkbolzen M24 - Ø30 - 110		0,93	
	600 035	Stabilisatorfeder		1,5	
	600 100	Hauptrahmen CW-F/H		205	
	600 101	Klappteil links CW-F 4032 H		45	
	600 102	Klappteil rechts CW-F 4032 H		45	
	600 103	Turmplatte CW-F/H 500-276-15		12	
	600 104	Turmrohr CW-F/H		7,6	

Ausgabe: A_0116 • Preisstand: PL112 • Ersatz für: *

KNOCHEN Maschinenbau GmbH • Tel.: +49-(0)-5723-9476-70 • Fax: +49-(0)-5723-9476-86 • www.knoche-maschinenbau.de

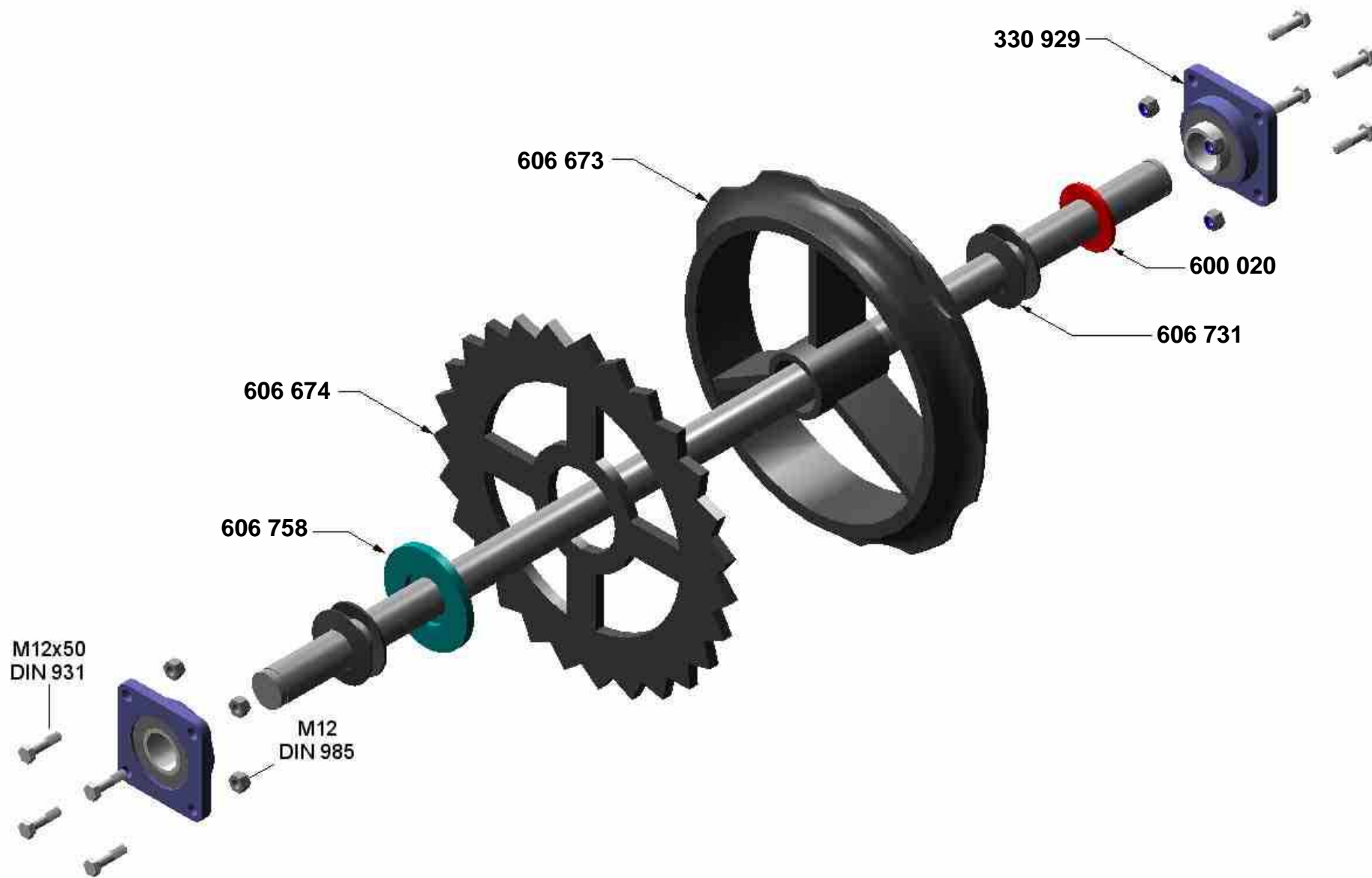



Typ		CW-F 51/4032 H		Baugruppe/ section/ groupe		Walzenelement		
POS	ID / part-no. réf. article	Benennung / description dénomination			Notiz / note note	Gewicht [kg] weight / poids	Preis [€] price / prix	
	330 929	Flanschlager UCF 210 / NP 50				2,68		
	600 020	Distanzscheibe 90-6-50				0,21		
	600 038	Welle 50x2750 - 22 Ringe				42,4		
	600 105	50er Welle -745 lg mit Nut Chromstahl				11,5		
	606 673	Walzenring, glatt 510				24		
	606 674	Reinigungsring, gez. 510				10		
	606 731	Tellerfeder 100 x 51 x 2,7				0,12		
	606 758	Sternringführung						

KNOECHE Maschinenbau GmbH • Tel.: +49-(0)-5723-9476-70 • Fax: +49-(0)-5723-9476-86 • www.knoeche-maschinenbau.de